

FITTING THE 19" RACK EARS

1) CHECK THE CONTENTS:

Please carefully check that both of the Rack Ears are present in the kit. They are not identical – one is for the left side and one is for the right.

1x ZED6010FXRK19 Rack Ears (AA8983-L/R)
8x M4x10 Pan torx screws (AB5680)
8x M4 Nylock nuts (AB0188)

1x ZED 10 19" Rack Ears Fitting Instructions (AP8990)

2) TOOLS REQUIRED:

25-30mm flat bladed screw driver
No.1 & No.2 Posi drivers
T10 & T20 Torx drivers
Small adjustable spanner or 5.5mm(M3) & 7mm(M4) sockets

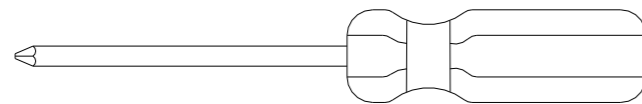

3) ENSURE POWER IS DISCONNECTED

Before attempting to fit the Rack Ears, remove all power to the unit and disconnect any signal cables where necessary.

4) DISMANTLING THE MIXER

To fit the Rack Ears it is necessary to firstly remove both plastic side trims which are attached with screws located inside the mixer.

Remove six M3x6mm screws under mixer (3 at front of base, 3 on rear of mixer).
Remove six cross-head screws on top panel (3 LHS,3 RHS),

See figure 1

Figure 1

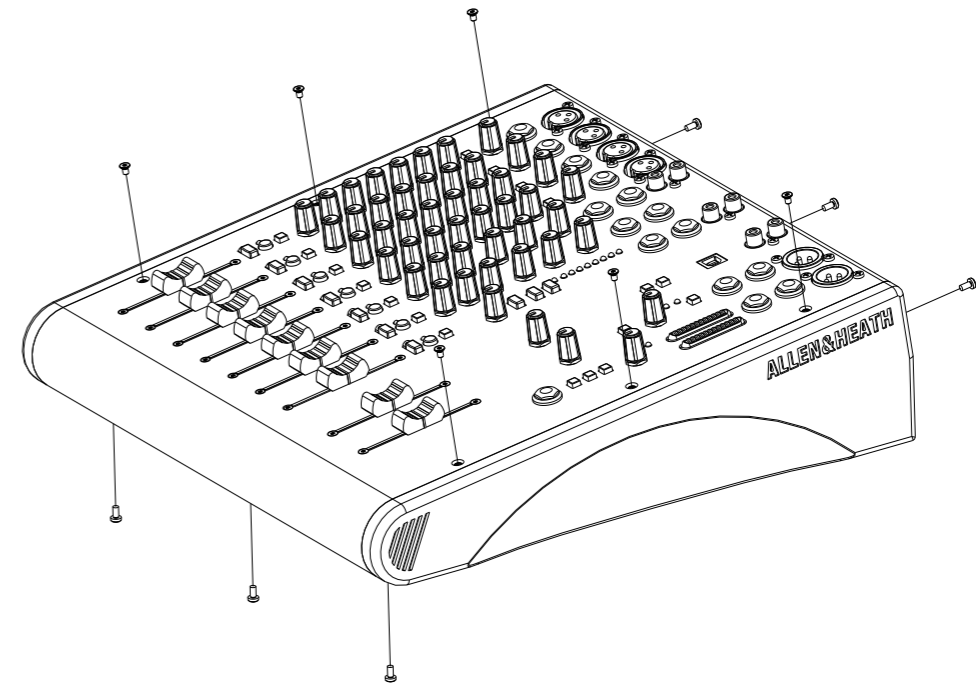

Carefully remove the top panel by gently pulling the back end upwards and sliding the panel forward. Place top panel on left hand side of mixer base. **Care must be taken not to pull on connecting power cable.**

It is now necessary to remove the power supply PCB which is fitted to the base panel. This is done by removing six M3x6mm screws. Please retain screws. It is not necessary to remove the Green/Yellow earthing wire, carefully move the power supply PCB to one side while removing side trim screws.

Note that the 2 screws on mains inlet socket also need to be unscrewed.

The plastic side trims can now be removed by unscrewing five cross-head screws from each side trim. In case the side trims will need to re-fitted at any time, we suggest the screws are 'partly' re-inserted (thereby avoiding possible internal damage) into the side trim for safe keeping.

Figure 2

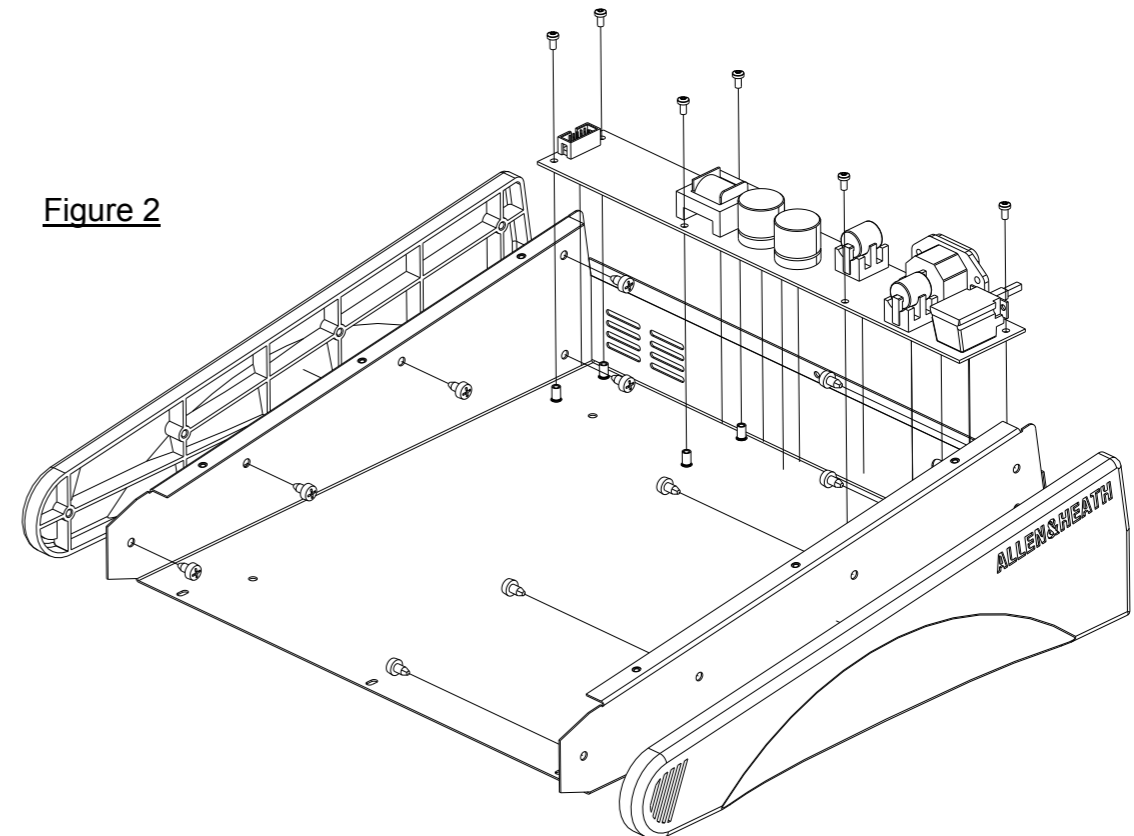

5) FIXING THE RACK EARS

Fit the rack ears to the left and right sides using eight M4x10mm screws and nylock nuts using a T20 driver. There are 4 on each side (To determine which rack ear is left or right, the fixing screw hole that is out of line with the others is the front one).

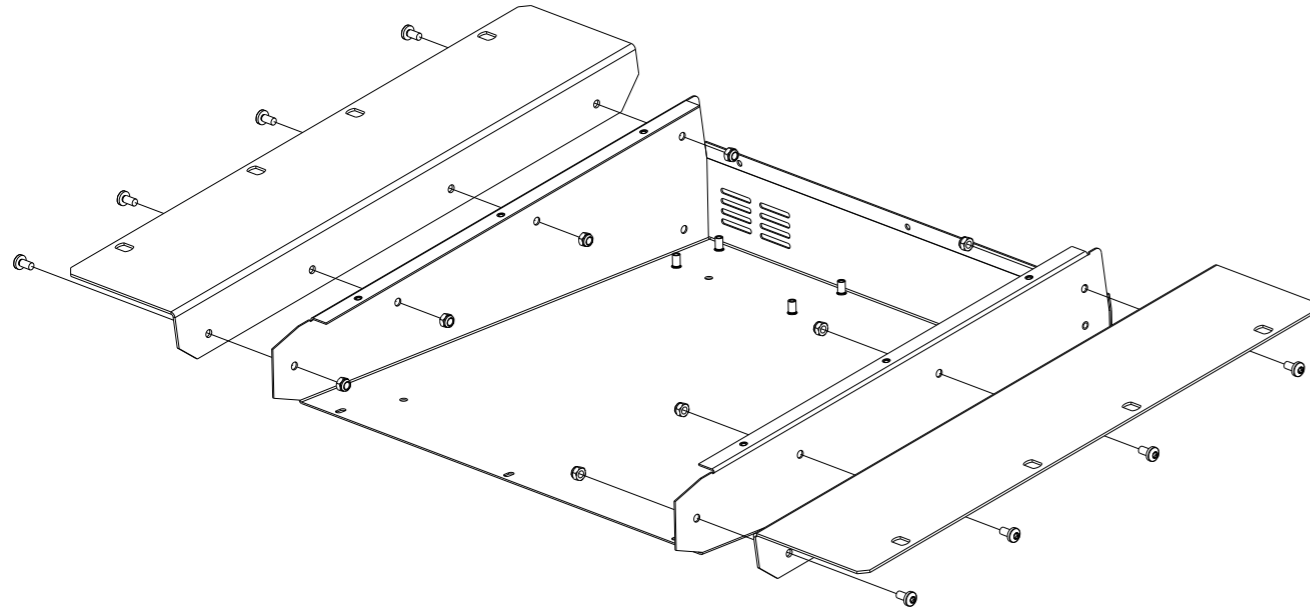

6) REASSEMBLING THE MIXER

Carefully re-fit the power supply PCB by firstly positioning PCB using the 6 screw holes in the mixer base with those on the PCB, re-fit with six M3x6mm screws taking care not to over tighten. The complete top section can now be re-fitted to the base taking care not to trap the power cable. Fit the six cross-head screws to the front panel first, then the six M3x6mm screws to the base and back panel of unit.

7) RACK INSTALLATION

Secure the assembly to the rack using suitable rack screws and washers.

ALLEN&HEATH

Allen & Heath Limited
Kernick Industrial Estate,
Penryn,
Cornwall TR10 9LU
U.K.
Tel: 44 (0) 1326 372070
Fax: 44 (0) 1326 377097
<http://www.allen-heath.com>

ALLEN&HEATH



19" RACK EARS OPTION

This option enables you to fit 19" Rack Ears to ZED60 10FX mixer.

Kit Part No: ZED6010FX-RK19

FITTING INSTRUCTIONS

Publication AP8990

Issue 4