

MODEL MX200 SERIES MICROPHONES



FEATURES

- Wide dynamic range and frequency response for accurate sound reproduction across the audio spectrum
- Interchangeable cartridges that provide an optimal polar pattern choice for each application
- Supplied stand-mount adapter for portable applications (in-line preamplifier versions only)
- White or black finish that blends unobtrusively with most surroundings
- New RF filtering

SPECIFICATIONS

Frequency Response (Figure 1)

50 to 17,000 Hz

Polar Pattern (Figure 2)

Output Impedance

EIA Rated at 150 Ω (180 Ω actual)

Sensitivity (At 1,000 Hz, open circuit voltage*)

Cardioid: -35.0 dBV/Pa (17.8 mV)

Supercardioid: -33.5 dBV/Pa (21.1 mV)

Omnidirectional: -27.5 dBV/Pa (42.2 mV)

*1 Pascal = 94 dB SPL

Maximum SPL (1 kHz at 1% THD, 1 k Ω load)

Cardioid: 124.2

Supercardioid: 122.7 dB

Omnidirectional: 116.7 dB

Equivalent Output Noise (A-weighted)

Cardioid: 28.0 dB SPL

Supercardioid: 26.5 dB SPL

Omnidirectional: 20.5 dB SPL

Signal to Noise Ratio (referenced at 94 dB SPL)

Cardioid: 66.0

Supercardioid: 67.5 dB

Omnidirectional: 73.5 dB

Shure Microflex MX200 Series microphones are miniature electret condenser microphones designed for miking choirs and performance groups. They are typically suspended over the heads of the performers. Their high sensitivity and wide frequency range make them suitable for recording, as well as sound reinforcement applications. An attached 101 mm (4 in.) gooseneck allows them to be easily aimed at the sound source.

Dynamic Range at 1 k Ω Load

96.2 dB

Common Mode Rejection

45.0 dB minimum

Preamplifier Output Clipping Level (1% THD)

-6.0 dBV (0.5 V)

Polarity

Positive sound pressure on diaphragm produces positive voltage on pin 2 relative to pin 3 of output connector.

Power Requirements

11 to 52 Vdc phantom, 2.0 mA

Environmental Requirements

Operating Temperature Range:

-18° C to 57° C (0° F to 135° F)

Relative Humidity: 0 to 95%

Dimensions (Figure 3)

CERTIFICATION

Eligible to bear CE Marking. Conforms to European EMC Directive 89/336/EEC. Meets applicable tests and performance criteria in European Standard EN55103 (1996) parts 1 and 2, for residential (E1) and light industrial (E2) environments.

REPLACEMENT PARTS

Omnidirectional Cartridge (Black)R183B
Omnidirectional Cartridge (White)R183W
Supercardioid Cartridge (Black)R184B
Supercardioid Cartridge (White)R184W
Cardioid Cartridge (Black)R185B
Cardioid Cartridge (White)R185W
Snap-Fit Windscreens (Black, 4 per pkg)RK183WS
In line preamplifier (Black)RK183PK
Preamplifier kit, plate mountedRK202PK
Stand Adaptor65B1752
In-Line Preamplifier (Black)RK100PK/B
In-Line Preamplifier (White)RK100PK/W

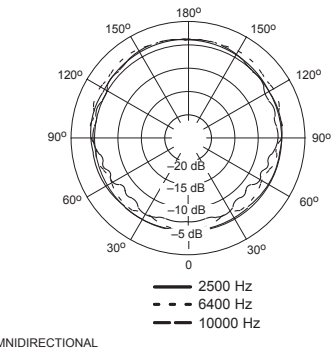
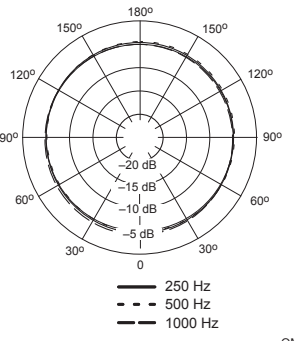
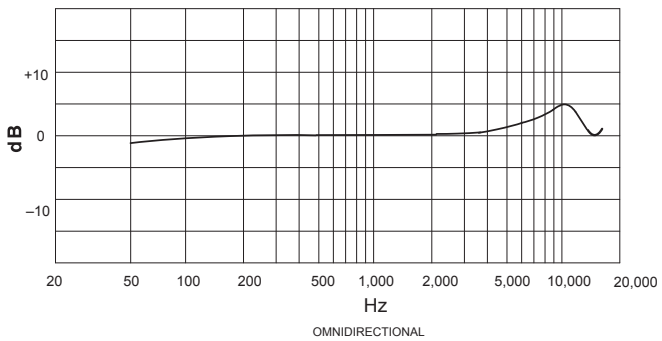
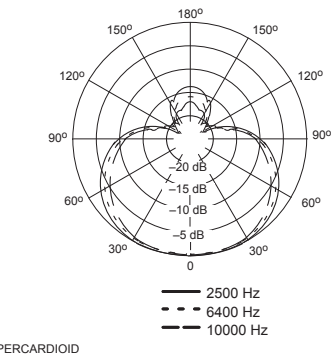
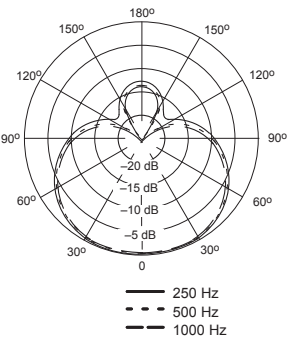
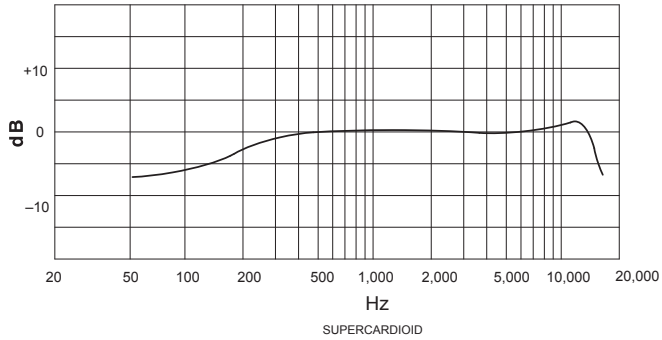
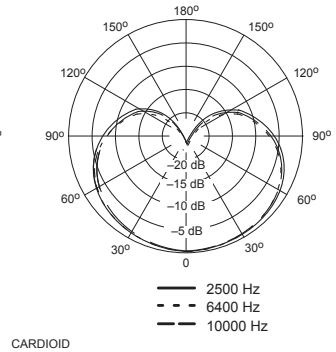
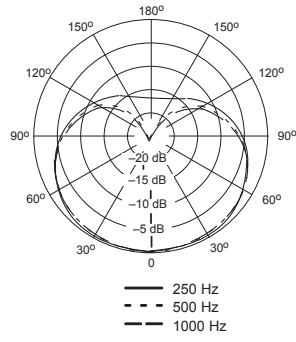
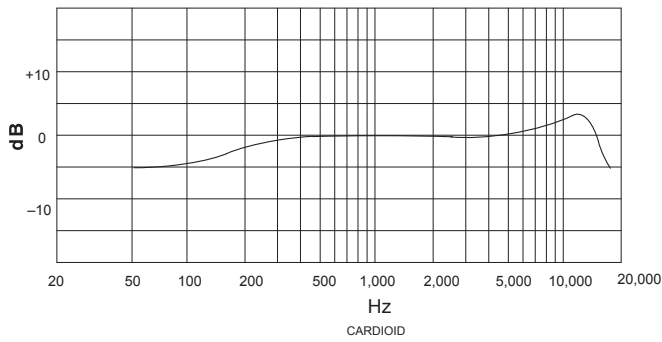

TYPICAL FREQUENCY RESPONSE
FIGURE 1

TYPICAL POLAR PATTERNS
FIGURE 2

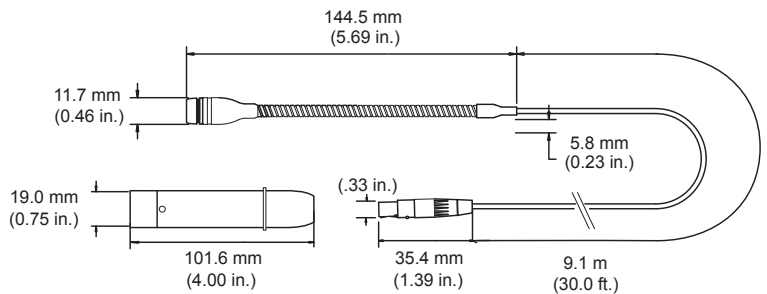
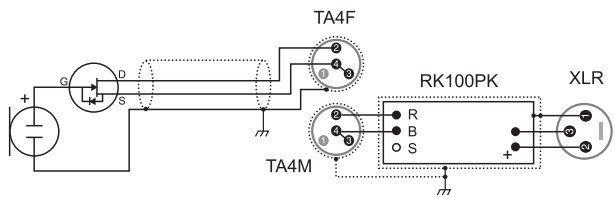

DIMENSIONS
FIGURE 3



SHURE Incorporated <http://www.shure.com>
 United States, Canada, Latin America, Caribbean:
 5800 W. Touhy Avenue, Niles, IL 60714-4608, U.S.A.
 Phone: 847-600-2000 U.S. Fax: 847-600-1212 Int'l Fax: 847-600-6446
 Europe, Middle East, Africa:
 Shure Europe GmbH, Phone: 49-7262-92490 Fax: 49-7262-9249114
 Asia, Pacific:
 Shure Asia Limited, Phone: 852-2893-4290 Fax: 852-2893-4055